

LAN CONTROLLER

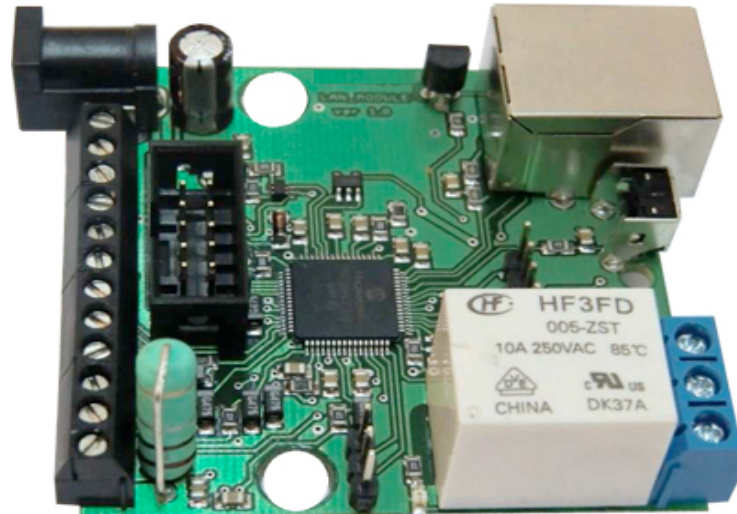

RESTARTER, MONITOR, WATCHDOG, CONTROLLER

FEATURES:

- WWW or SNMP v2 management.
- firmware upgrade via TFTP
- read data in real time without refresh page
- possibility switch on/off to 5 relay direct from page WWW
- events panel to self-programming by user
- Scheduler (switch on/off output for definite time in week days)
- Watchdog IP to five IP device
- monitoring of additional devices eg. sensors
- measurement: environment temperature, supply voltage, temperature and current from connected sensors
- power measurement for DC voltage
- possibility connection of the additional board with RJ45 ports (4 LAN Input, 4 ye LAN + PoE) or additional board with 4 relays
- Set time manually or by server NTP
- Possibility sensors calibration
- steering frequency and duty PWM
- e-mail notification about programmed events
- SNMP TRAP notification about programmed events
- Automatic send SNMP TRAP with state or value inputs
- implement protocols: HTTP, SNMP, SMTP, SNTP, ICMP, DNS, DHCP.
- service temperature sensors: NTC10K B=3950, KTY-84, PT1000, DS18B20

Default user and password is „admin”, IP address is 192.168.1.100

TECHNICAL SPECIFICATIONS

- supply voltage: 8-56V (from 6V- if don't use measurement current and PT1000)
- power consumption : about 1W
- PoE supply: YES, passive
- Protection from wrong supply polarization: YES
- interface: ethernet 10Mbit/s
- relay: 255VAC 10A
- work temperature: -20 do +85 st. C
- weight 45g (without casing)
- casing type Z-67 (not included)
- dimensions 57x67mm

INPUT/OUTPUT:

- 1 RELAY to switch on/off/ another devices, available contact: NC and NO
- 4 OUTPUT to switch relays, ports PoE or another devices;
- 1 STEERABLE OUTPUT PWM from 2,6 KHz to 4Mhz;
- 2 LOGICAL INPUT (max 12V): to monitoring another devices, eg. bufor supply.
collaboration with outputs: OC,NO, NC

- **5 ANALOG INPUT:**

INP1: temperature measurement witch thermistor NTC 10K B=3950(from -40 to +120 °C) or thermistor KTY-84-130 (from -40 to +300°C), accuracy 1 °C (dependent on NTC)

INP2: thermistor NTC 10K or voltage measurement to 3,6V, with use additional divider increase range..

INP3: voltage measurement to 35V, accuracy +- 0,1V;

INP4: temperature measurement by PT1000 (from -20 to +850 °C) accuracy +- 2°C;

INP5: measurment DC current to 3A, accuracy +- 10mA;

- **MAGISTRALA 1-WIRE (złącze RJ11)** – to DS18B20 sensor

PINS and COMPONENTS DESCRIPTION

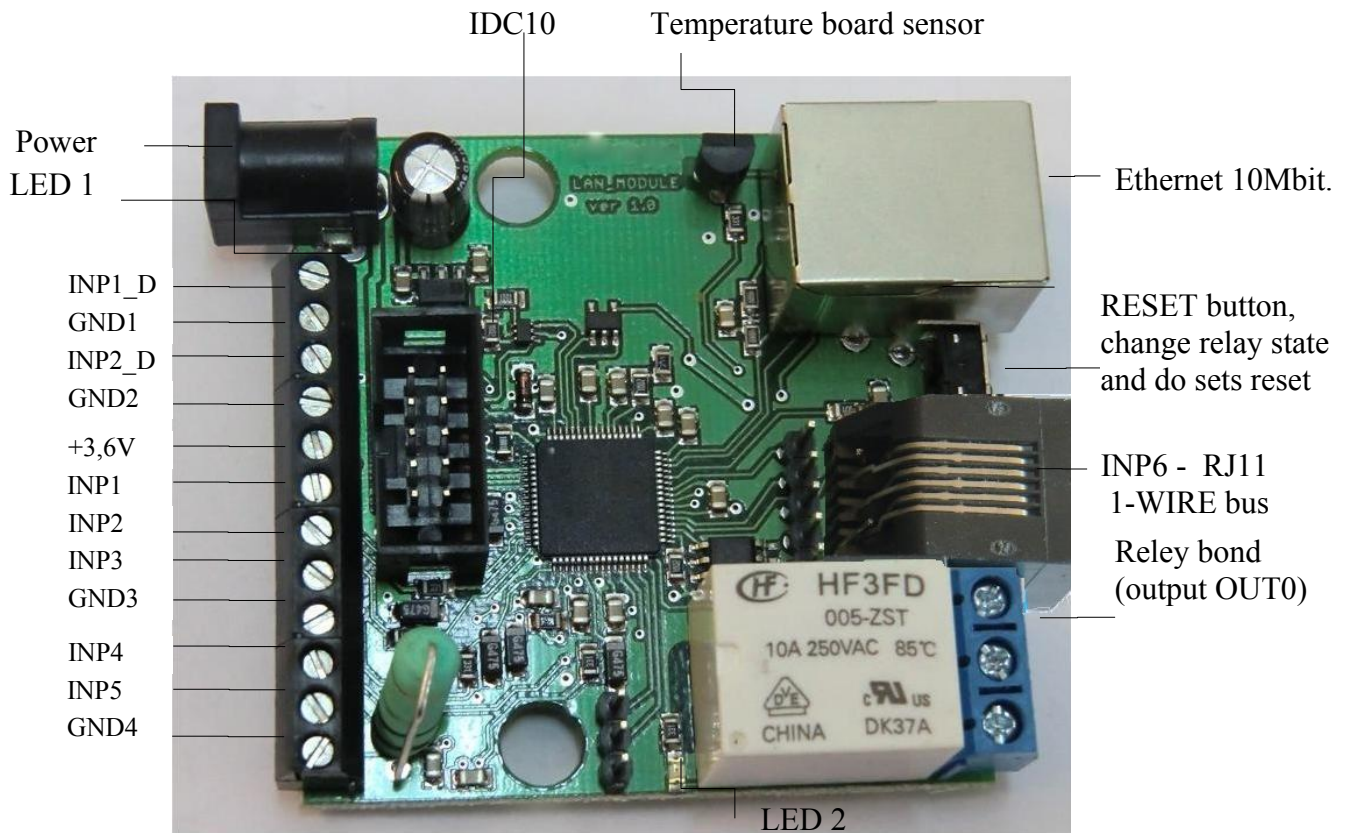

PIN/Component	Description
Power	Power suply 8V-56VDC or via PoE
RELAY bond	To connect external device, detail description below
LED1	Shine LED means Power on board
LED2	Shine LED means relay active
IDC10	To connect additional board , detail description below
INP1_D	Logical input 1
GND1	gnd for INP1_D and INP2_D or general gnd
INP2_D	Logical input 2
GND2	general gnd
+3,6V	Supply for sensors NTC-10K and KTY-84 connected to INP1 or INP2
INP1	input for sensor NTC-10K or voltage measurement max (without divider) 3,6V
INP2	input for sensor NTC-10K Or KTY-84-130
INP3	input for voltgae measerment max 35V
GND3	general gnd
INP4	input for sensor PT1000 or connected the same sensor in solar controller
INP5	Input for current measurement
GND4	Gnd for current measurement Or general if don't measurement current
INP6	Input for DS18B20 sensor (1-wire bus on RJ11 connector)

Relay Bond:

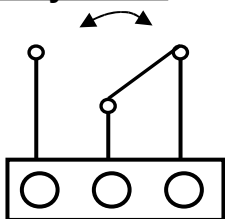

NO – contact normally open

CON – common contact

NZ – contact normally closed

NO CON NZ

ATTENTION: In spite of that relay can switch AC voltage 255 VAC 10A, board fail to comply with safety requirements (lack housing, earthing). Therefore that receiver connect with the assistance safety external relays eg. on DIN bus, controlled by relay on board.

IDC10 and RJ11

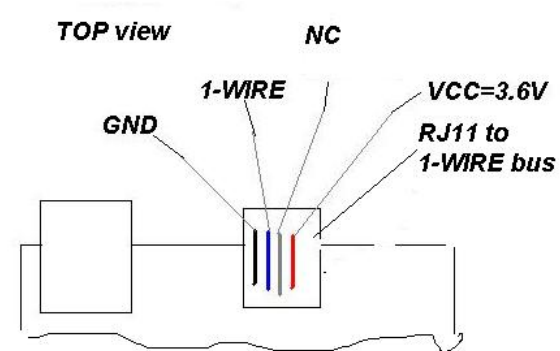
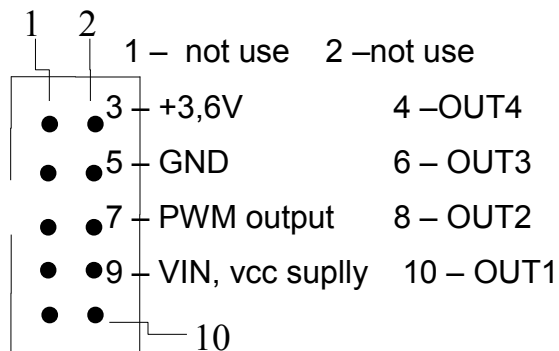

RESET BUTTON

Push about 0,5 second cause change relay state on opposite, push and keep longer about 5 second (if we not logged by WWW on modul) cause modul reset, next if you still keep button about 10 second cause set all settings to default. Set all settings to default confirmation is fast switch relay on/off (klik-klik), don't wrong this with change relay state about 0,5s and switch relay off after restart.

User and password: admin

IP: 192.168.1.100

Sensors connect

1. Current measurement.

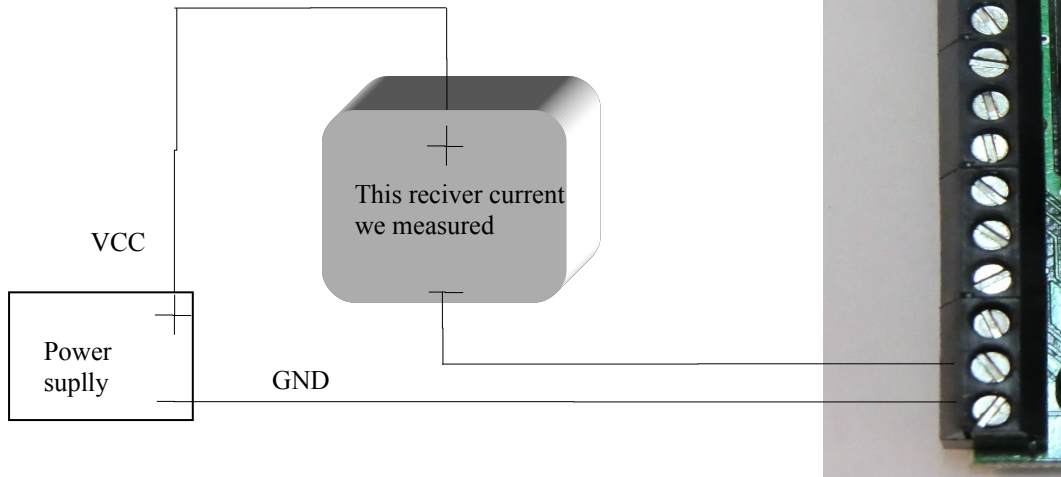

2. Temperature measurement and logical input.

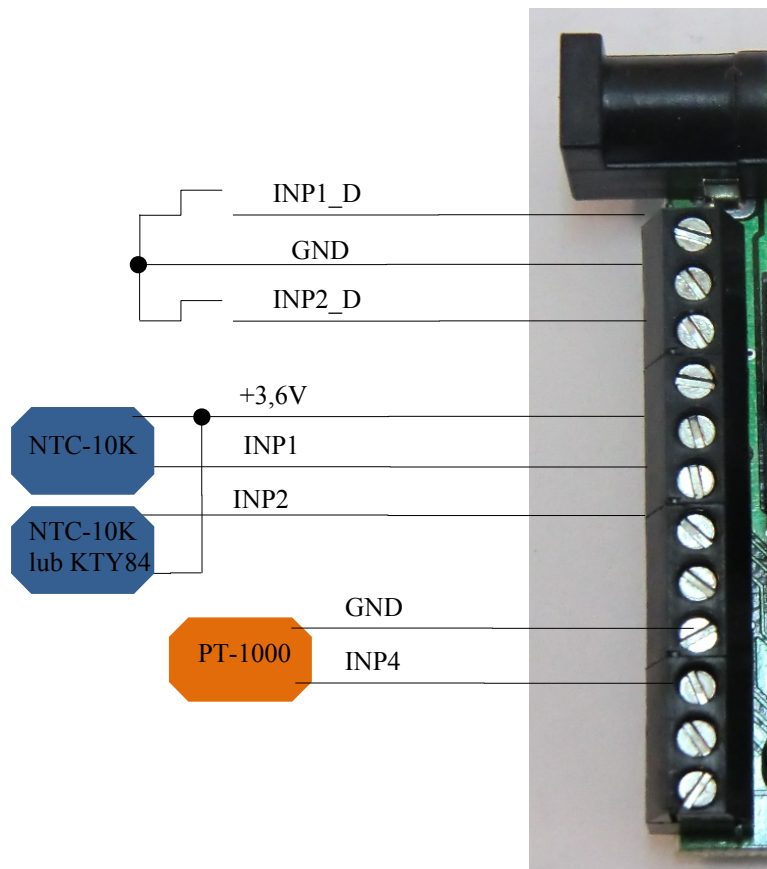

3. Voltage measurement.

INP1 is use to temperature measure or voltage, in control panel you must choice what you want measure

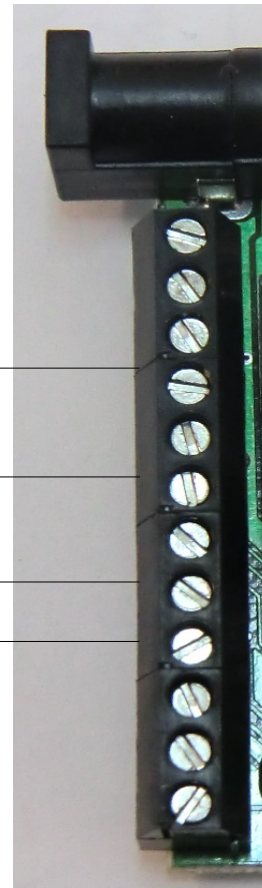
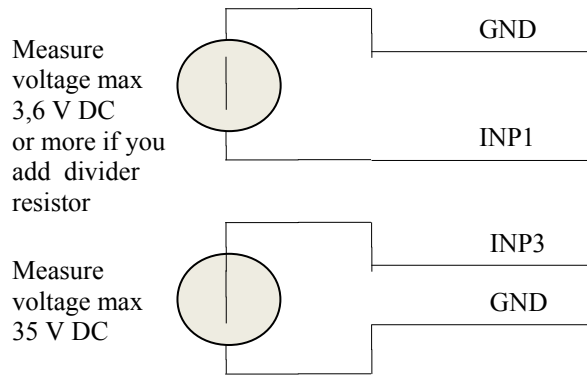

Additional resistor to increase measure range INP1



R = 10K increase range 2 (multiplier 2) that is $3,6V \times 2 = 7,2V$

R= 20 K increase range 3 (multiplier 3)

R= 30 K increase range 4 (multiplier 4) etc.

Add resistor must be connected with set proper multiplier in field VCC on control panel page.



Management by WWW.

1.Control Panel

Change outputs state display

Any text description, max 8 chars

CONTROL PANEL

VCC SUPPLY = 12.2 V
Board Temperature= 27.3 °C

Digital Outputs Control

Reverse out state
 Reset time
|Out0| Out1| Out2| Out3| Out4|

Out0
OFF
●

Out1
OFF
●

Out2
OFF
●

Out3
OFF
●

Out4
OFF
●

1
2
3
4
5

PWM Output OFF

Frequency = Hz 5008

Duty = % 50.0

ANALOG Inputs State

Input	Value	Unit	kal	Sensor type	
Inp1	n/a	°C	<input type="text" value="0.0"/>	<input checked="" type="radio"/> TEMP	<input type="radio"/> VCC <input type="text" value="1"/>
Inp2	n/a	°C	<input type="text" value="0.0"/>	<input checked="" type="radio"/> NTC10	<input type="radio"/> KTY84
Inp3	0.0	V	<input type="text" value="0.0"/>		
Inp4	n/a	°C	<input type="text" value="0.0"/>	<input checked="" type="radio"/> PT	<input type="radio"/> SOLAR
Inp5	0.00	A	<input type="text" value="0.00"/>		
Inp6	n/a	°C		<input type="radio"/> DS18B20	<input type="radio"/> 1-Wire
Power measure					
I3*I5	0.00	W			
P*t	0.000	Wh		<input type="button" value="Start"/>	<input type="button" value="Reset"/>

DIGITAL Inputs State

Input 1 Input 2
HIGH HIGH

- Push red or green circle to change output state or chose "Set State" button
- Reset time=0 normal outputs work ON/OFF

Klik cause change relay state on opposite (OUT0 relay on board)

Set state All output simultaneously according to combo box

Run PWM generator

Value of calibration

Run Power measure from INP3 (voltage) and INP5 (current)

Chose type connected sensor

Reset time – for 0 normal outputs work (ON/OFF) , for time > 0 output after push button change state and return to state before after the specified time in seconds (max 65534).

2.Events Config (events panel)

Delay of set outputs after occur events, in seconds max 65535

Events Config									
INPUTS	OUTPUTS/ACTION								
HYSTERESIS	OUT0	OUT1	OUT2	OUT3	OUT4	PWM	E-MAIL	SNMP TRAP	
TEMP <input type="checkbox"/>	100.0 0.0	100.0 0.0	100.0 0.0	100.0 0.0	100.0 0.0	100.0 0.0 0 Hz 0.0 %	100.0 0.0 text0	100.0 0.0	
VCC SUPPLY <input checked="" type="checkbox"/>	100.0 0.0	100.0 0.0	100.0 0.0	100.0 0.0	100.0 0.0	100.0 0.0 0 Hz 0.0 %	100.0 0.0 text1	100.0 0.0	
INP1 °C <input checked="" type="checkbox"/>	100.0 0.0	100.0 0.0	100.0 0.0	100.0 0.0	100.0 0.0	100.0 0.0 0 Hz 0.0 %	100.0 0.0 text2	100.0 0.0	
INP2 °C <input checked="" type="checkbox"/>	100.0 0.0	100.0 0.0	100.0 0.0	100.0 0.0	100.0 0.0	100.0 0.0 0 Hz 0.0 %	100.0 0.0 text3	100.0 0.0	
INP3 V <input checked="" type="checkbox"/>	100.0 0.0	100.0 0.0	100.0 0.0	100.0 0.0	100.0 0.0	100.0 0.0 0 Hz 0.0 %	100.0 0.0 text4	100.0 0.0	
INP4 °C <input checked="" type="checkbox"/>	100.0 0.0	100.0 0.0	100.0 0.0	100.0 0.0	100.0 0.0	100.0 0.0 0 Hz 0.0 %	100.0 0.0 text5	100.0 0.0	
INP5 A <input type="checkbox"/>	10.00 0.00	10.00 0.00	10.00 0.00	10.00 0.00	10.00 0.00	10.00 0.00 0 Hz 0.0 %	10.00 0.00 text6	10.00 0.00	
INP6 °C <input checked="" type="checkbox"/>	100.0 0.0	100.0 0.0	100.0 0.0	100.0 0.0	100.0 0.0	100.0 0.0 0 Hz 0.0 %	100.0 0.0 text7	100.0 0.0	
INP1 DIG	<input type="checkbox"/>	<input type="checkbox"/>	<input type="checkbox"/>	<input type="checkbox"/>	<input type="checkbox"/>	<input type="checkbox"/> 0 Hz 0.0 %	text8	<input type="checkbox"/>	
INP2 DIG	<input type="checkbox"/>	<input type="checkbox"/>	<input type="checkbox"/>	<input type="checkbox"/>	<input type="checkbox"/>	<input type="checkbox"/> 0 Hz 0.0 %	text9	<input type="checkbox"/>	

Save Config

- Value of hysteresis
- ON/OFF input
- When signal cross up this value output will be set ON Or generator PWM start or send e_mail or SNMP Trap
- When signal cross down this value output will be set ON Or generator PWM start or send e_mail or SNMP Trap
- Save settings (ON/OFF input you don't must save)
- If check, means that is ON
- Email text that will be send if events occurrence, max amount char is 79. Chars „=" and „& are not allowed

For logical input INP1D and INP2D, e-mail and SNMP Trap notification are send when input level change from 1 to 0 or 0 to 1, additional to email text (at end) will be add value 1 or 0 mark actual input state.

Config events description:

Example:

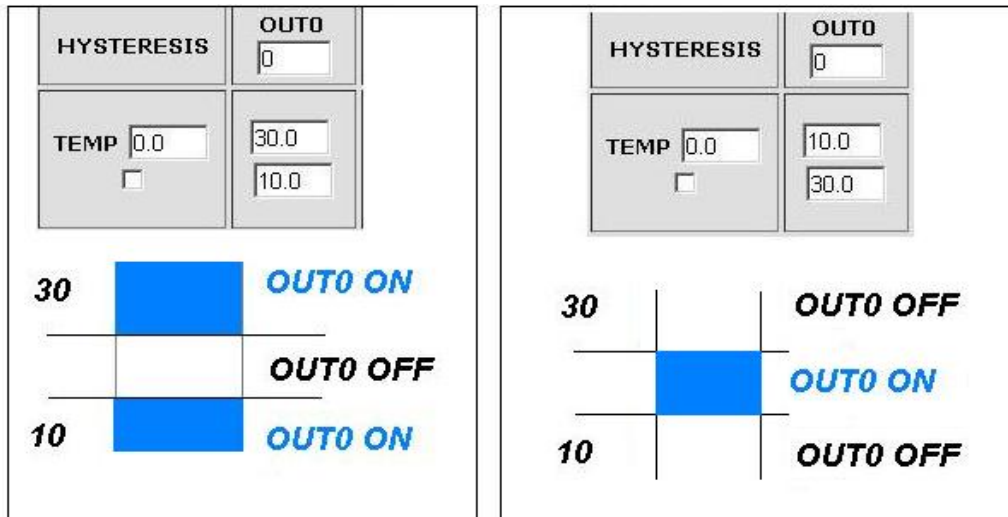

3.Watchdog

WatchDog

Enable IP0
IP0 168.1.10.10 OUT0: ON | OFF | RESET= 768 s | PING Failures 2

Enable IP1
IP1 168.1.10.10 OUT1: ON | OFF | RESET= 768 s | PING Failures 2

Enable IP2
IP2 168.1.10.10 OUT2: ON | OFF | RESET= 768 s | PING Failures 0

Enable IP3
IP3 168.1.10.10 OUT3: ON | OFF | RESET= 768 s | PING Failures 0

Enable IP4
IP4 168.1.10.10 OUT4: ON | OFF | RESET= 768 s | PING Failures 0

30 s Wait time - before again ping, after event

Save Config

Time to wait for respond is 4s

When events occur, next ping to this same IPX will be send after this time (max 65535second)

Amount PING failures, after this one of three events will be happen:
set (ON) output,
set (OFF) output
reset (ON/OFF) output on definite time (max 65535s).

Time to respond is 4 second, after this time one PING failures is counting. In time waiting to respond, another IPX aren't send ping, this may causa stretch time statment that another IPX adress is inaccessible.

4.Scheduler

Scheduler

DATE and TIME: Th-1970-01-01;00:00:10

<input type="checkbox"/> Enable S0	<input type="text" value="0,Mo,00:00:00"/>	<input checked="" type="radio"/> ON	<input type="radio"/> OFF	<input type="radio"/> RESET = <input type="text" value="10"/>
<input type="checkbox"/> Enable S1	<input type="text" value="0,Mo,00:00:00"/>	<input checked="" type="radio"/> ON	<input type="radio"/> OFF	<input type="radio"/> RESET = <input type="text" value="10"/>
<input type="checkbox"/> Enable S2	<input type="text" value="0,Mo,00:00:00"/>	<input checked="" type="radio"/> ON	<input type="radio"/> OFF	<input type="radio"/> RESET = <input type="text" value="10"/>
<input type="checkbox"/> Enable S3	<input type="text" value="0,Mo,00:00:00"/>	<input checked="" type="radio"/> ON	<input type="radio"/> OFF	<input type="radio"/> RESET = <input type="text" value="10"/>
<input type="checkbox"/> Enable S4	<input type="text" value="0,Mo,00:00:00"/>	<input checked="" type="radio"/> ON	<input type="radio"/> OFF	<input type="radio"/> RESET = <input type="text" value="10"/>
<input type="checkbox"/> Enable S5	<input type="text" value="0,Mo,00:00:00"/>	<input checked="" type="radio"/> ON	<input type="radio"/> OFF	<input type="radio"/> RESET = <input type="text" value="10"/>
<input type="checkbox"/> Enable S6	<input type="text" value="0,Mo,00:00:00"/>	<input checked="" type="radio"/> ON	<input type="radio"/> OFF	<input type="radio"/> RESET = <input type="text" value="10"/>
<input type="checkbox"/> Enable S7	<input type="text" value="0,Mo,00:00:00"/>	<input checked="" type="radio"/> ON	<input type="radio"/> OFF	<input type="radio"/> RESET = <input type="text" value="10"/>
<input type="checkbox"/> Enable S8	<input type="text" value="0,Mo,00:00:00"/>	<input checked="" type="radio"/> ON	<input type="radio"/> OFF	<input type="radio"/> RESET = <input type="text" value="10"/>
<input type="checkbox"/> Enable S9	<input type="text" value="0,Mo,00:00:00"/>	<input checked="" type="radio"/> ON	<input type="radio"/> OFF	<input type="radio"/> RESET = <input type="text" value="10"/>

Week Day

Mo-Monday, Tu- Tuesday, We- Wednesday, Th- Thursday, Fi- Friday, Sa- Saturday,
Su-Sunday, ## - all week day

Letter size is important

Format: number output(from 0 to 4),day1,day2,day3,day4,day5,day6, xx:xx:xx(time)

Example:

0,Mo,12:23:00 sets out0 every Monday at 12:23:00

1,Sa;Fi,Mo,23:22:03 sets out1 every Saturday, Friday and Monday at 23:22:03

1,Sa;Fi,Mo,Tu,Su,Th,23:22:03 sets out1 every Saturday, Friday, Monday, Tuesday,
Sunday and Thursday at 23:22:03

0,##,12:01:30 - sets out0 every week day at 12:01:30

Reset – time in second (max 65535).

Network Configuration.

Network Configuration

Email client settings

SMTP Server:	<input type="text" value="smtp.serwer.pl"/>	Port:	<input type="text" value="25"/>
User Name:	<input type="text" value="user"/>		
Password:	<input type="text" value="user"/>		
To:	<input type="text" value="user@com.pl"/>		
From:	<input type="text" value="lan_restarter@com.pl"/>		
Subject:	<input type="text" value="Lan Restarter Info"/>		
	<input type="button" value="Save Config"/>	<input type="button" value="Test e-mail send"/>	

When you change setting press "Save Config" before Test

Network settings

MAC Address:	<input type="text" value="00:04:A3:35:08:43"/>
Host Name:	<input type="text" value="LAN_SWITCH-SENS"/>
	<input type="checkbox"/> Enable DHCP
IP Address:	<input type="text" value="192.168.1.100"/>
Gateway:	<input type="text" value="192.168.1.1"/>
Subnet Mask:	<input type="text" value="255.255.255.0"/>
Primary DNS:	<input type="text" value="192.168.1.2"/>
Secondary DNS:	<input type="text" value="0.0.0.0"/>
	<input type="button" value="Save Config and Reboot"/>

ACCESS settings

User:

Password:
Max char 8

NTP settings

NTP Server: Port:

Time Interval:

Time Zone:

SNMP settings

Read Comm1:

Read Comm2:

Read Comm3:

Write Comm1:

Write Comm2:

Write Comm3:

TRAP Enable

Trap Reciver IP:

Trap Comm:

Time Interwal - minuts.

TRAP Enable – enabled send TRAP by SNMP.

AUTO SEND TRAP settings

Enable Automatic Send TRAP

TEMP

VCC

INP1

INP2

INP3

INP4

INP5

INP1D

INP2D

Time Interval: * 10s = 0.17m

Date and Time

NTP: ON

Set Manual:

Relay after start

OUT0: ON

OUT1: ON

OUT2: ON

OUT3: ON

OUT4: ON

Enable Automatic Send TRAP – enable automatic send TRAP by SNMP (above TRAP Enable must be enable)

Time Interval (max value 10555) – period to send TRAP from given INPUT, accuracy 10 s

Relay state after start

Firmware Upgrade.

You may upgrade firmware on two ways:

1. By dedicated software „LAN Controller Tools”(find controller or put IP and click „Upgrade Firmware”).
2. By any TFTP client, description below.

Send firmware file by TFTP, you have 5 seconds (Green LED on RJ45 socket blink) to start sending firmware when the module runs after reset (you may reset by clicking the button „Save config and Reboot” in Network configuration or „Reset” button on board or dedicated software „LAN Controller Tools”). If the start transmission does not happen, the device starts working normally. If TFTP transmission will start, then wait about 90 seconds to finish uploading firmware. After uploading, the device will be reset and start normally.

If you want to upload the upgrade file, choose „Save config and Reboot” in Network configuration or power OFF and power ON the device.

The file must be sent in binary mode eg. In Windows XP tftp client
tftp -i 192.168.1.100 put „file_upgrade.bin”.



```
C:\>C:\SYSWXP\system32\cmd.exe
C:\>tftp -i 192.168.1.100 put "firmware_lan_1.0.bin"
Przesłano pomyślnie: bajtów: 321664 w 79 ss, bajtów/s: 4071
C:\>_
```

OID dla SNMP

SYS_UP_TIME // 43.6.1.2.1.1.3: READONLY TIME_TICKS.
TRAP_RECEIVER_ID // 43.6.1.4.1.17095.2.1.1.1: READWRITE BYTE.
TRAP_RECEIVER_ENABLED // 43.6.1.4.1.17095.2.1.1.2: READWRITE BYTE.
TRAP_RECEIVER_IP // 43.6.1.4.1.17095.2.1.1.3: READWRITE IP_ADDRESS.
TRAP_COMMUNITY //43.6.1.4.1.17095.2.1.1.4: READWRITE ASCII_STRING.
OUT0 // 43.6.1.4.1.17095.3.1: READWRITE BYTE.
OUT1 // 43.6.1.4.1.17095.3.2: READWRITE BYTE.
OUT2 // 43.6.1.4.1.17095.3.3: READWRITE BYTE.
OUT3 // 43.6.1.4.1.17095.3.4: READWRITE BYTE.
OUT4 // 43.6.1.4.1.17095.3.5: READWRITE BYTE.
TEMP // 43.6.1.4.1.17095.3.6: READONLY ASCII_STRING.
VCC // 43.6.1.4.1.17095.3.7: READONLY ASCII_STRING.
INP1 // 43.6.1.4.1.17095.3.8: READONLY ASCII_STRING.
INP2 // 43.6.1.4.1.17095.3.9: READONLY ASCII_STRING.
INP3 // 43.6.1.4.1.17095.3.10: READONLY ASCII_STRING.
INP4 // 43.6.1.4.1.17095.3.11: READONLY ASCII_STRING.
INP5 // 43.6.1.4.1.17095.3.12: READONLY ASCII_STRING.
INP6 // 43.6.1.4.1.17095.3.13: READONLY ASCII_STRING.
I3XI5 // 43.6.1.4.1.17095.3.14: READONLY ASCII_STRING.
PXT // 43.6.1.4.1.17095.3.15: READONLY ASCII_STRING.
INP1D // 43.6.1.4.1.17095.3.16: READONLY BYTE.
INP2D // 43.6.1.4.1.17095.3.17: READONLY BYTE.

MIB file to SNMP application

LAN-MODULE DEFINITIONS ::= BEGIN

IMPORTS

enterprises, IpAddress, Gauge, TimeTicks FROM RFC1155-SMI
DisplayString FROM RFC1213-MIB
OBJECT-TYPE FROM RFC-1212
TRAP-TYPE FROM RFC-1215;

lan-module OBJECT IDENTIFIER ::= { enterprises 17095 }

product OBJECT IDENTIFIER ::= { lan-module 1 }

setup OBJECT IDENTIFIER ::= { lan-module 2 }

control OBJECT IDENTIFIER ::= { lan-module 3 }

ON-OFF ::= INTEGER { ON(1), OFF(0) }

name OBJECT-TYPE

SYNTAX DisplayString

ACCESS read-only

STATUS mandatory

DESCRIPTION

"Name of product. e.g. PICDEM.net etc."

::= { product 1 }

version OBJECT-TYPE

SYNTAX DisplayString

ACCESS read-only

STATUS mandatory

DESCRIPTION

"Version string. e.g. 1.0"

::= { product 2 }

date OBJECT-TYPE

SYNTAX DisplayString

ACCESS read-only

STATUS mandatory

DESCRIPTION

"Date of version"
::= { product 3 }

out0 OBJECT-TYPE
SYNTAX INTEGER { OFF(1), ON(0) }
ACCESS read-write
STATUS mandatory
DESCRIPTION
 "OUT0 output set or read"
::= { control 1 }

out1 OBJECT-TYPE
SYNTAX INTEGER { OFF(1), ON(0) }
ACCESS read-write
STATUS mandatory
DESCRIPTION
 "OUT1 output set or red"
::= { control 2 }

out2 OBJECT-TYPE
SYNTAX INTEGER { OFF(1), ON(0) }
ACCESS read-write
STATUS mandatory
DESCRIPTION
 "OUT2 output set or red"
::= { control 3 }

out3 OBJECT-TYPE
SYNTAX INTEGER { OFF(1), ON(0) }
ACCESS read-write
STATUS mandatory
DESCRIPTION
 "OUT3 output set or red"
::= { control 4 }

out4 OBJECT-TYPE
SYNTAX INTEGER { OFF(1), ON(0) }
ACCESS read-write
STATUS mandatory
DESCRIPTION
 "OUT4 output set or red"

::= { control 5 }

temp OBJECT-TYPE

SYNTAX DisplayString (SIZE (0..15))

ACCESS read-only

STATUS mandatory

DESCRIPTION

"Temp value: Air temperature around board"

::= { control 6 }

vcc OBJECT-TYPE

SYNTAX DisplayString (SIZE (0..15))

ACCESS read-only

STATUS mandatory

DESCRIPTION

"VCC value: Input VCC supply board"

::= { control 7 }

inp1 OBJECT-TYPE

SYNTAX DisplayString (SIZE (0..15))

ACCESS read-only

STATUS mandatory

DESCRIPTION

"Inp1 value: temperature from NTC10 or voltage"

::= { control 8 }

inp2 OBJECT-TYPE

SYNTAX DisplayString (SIZE (0..15))

ACCESS read-only

STATUS mandatory

DESCRIPTION

"Inp2 value: temperature from NTC10 or KTY-84"

::= { control 9 }

inp3 OBJECT-TYPE

SYNTAX DisplayString (SIZE (0..15))

ACCESS read-only

STATUS mandatory

DESCRIPTION

"Inp3 value: voltage max 35V DC"

::= { control 10 }

inp4 OBJECT-TYPE

SYNTAX DisplayString (SIZE (0..15))

ACCESS read-only

STATUS mandatory

DESCRIPTION

"Inp4 value: temperature from PT1000 or PT1000 connected to Solar System Controller"

::= { control 11 }

inp5 OBJECT-TYPE

SYNTAX DisplayString (SIZE (0..15))

ACCESS read-only

STATUS mandatory

DESCRIPTION

"Inp5 value: DC current, max 3A"

::= { control 12 }

inp6 OBJECT-TYPE

SYNTAX DisplayString (SIZE (0..15))

ACCESS read-only

STATUS mandatory

DESCRIPTION

"Inp6 value: temperature from DS18B20"

::= { control 13 }

i3xi5 OBJECT-TYPE

SYNTAX DisplayString (SIZE (0..15))

ACCESS read-only

STATUS mandatory

DESCRIPTION

"I3xi5 value: Power[W] from Input3 [V] and Input5[A]"

::= { control 14 }

Pxt OBJECT-TYPE

SYNTAX DisplayString (SIZE (0..15))

ACCESS read-only

STATUS mandatory

DESCRIPTION

"Pxt value: Energy[Wh] from Input3 and Input5 "

::= { control 15 }

inp1Digital OBJECT-TYPE
SYNTAX INTEGER { HIGH(1), LOW(0) }
ACCESS read-only
STATUS mandatory
DESCRIPTION
 "INP1D Digital state"
 ::= { control 16 }

inp2Digital OBJECT-TYPE
SYNTAX INTEGER { HIGH(1), LOW(0) }
ACCESS read-only
STATUS mandatory
DESCRIPTION
 "INP2D Digital state"
 ::= { control 17 }

traps OBJECT-TYPE
SYNTAX SEQUENCE OF TrapEntry
ACCESS not-accessible
STATUS mandatory
DESCRIPTION
 "Trap table"
 ::= { setup 1 }

trapEntry OBJECT-TYPE
SYNTAX TrapEntry
ACCESS not-accessible
STATUS mandatory
DESCRIPTION
 "Single trap entry containing trap receiver info."
INDEX { trapReceiverNumber }
 ::= { traps 1 }

trapEntry ::=

```
SEQUENCE {
    trapReceiverNumber
        INTEGER,
    trapEnabled
        INTEGER,
```

```
trapReceiverIPAddress  
  IpAddress,  
trapCommunity  
  DisplayString  
}
```

trapReceiverNumber OBJECT-TYPE

```
SYNTAX INTEGER (0.. 4)  
ACCESS not-accessible  
STATUS mandatory  
DESCRIPTION  
  "Index of trap receiver"  
 ::= { trapEntry 1 }
```

trapEnabled OBJECT-TYPE

```
SYNTAX INTEGER { Yes(1), No(0) }  
ACCESS read-write  
STATUS mandatory  
DESCRIPTION  
  "Indicates if this trap entry is enabled or not."  
 ::= { trapEntry 2 }
```

trapReceiverIPAddress OBJECT-TYPE

```
SYNTAX IpAddress  
ACCESS read-write  
STATUS mandatory  
DESCRIPTION  
  "Trap receiver IP address"  
 ::= { trapEntry 3 }
```

trapCommunity OBJECT-TYPE

```
SYNTAX DisplayString (SIZE (0..7))  
ACCESS read-write  
STATUS mandatory  
DESCRIPTION  
  "Trap community to be used by agent to send trap"  
 ::= { trapEntry 4 }
```

END

